

NO.	DATE	BY	SUBMITTALS / REVISIONS
1	12/22/23	KR	ISSUED TO CITY OF DELTONA

**LEHA BUSINESS PARK
 FINAL ENGINEERING PLANS
 MASTER DEVELOPMENT PLAN**

PROJECT NO:	ZC 22141
DESIGNED BY:	KR
DRAFTED BY:	CM
CHECKED BY:	KR
DRAWING FILE:	02_22141 ODP
XREFS:	XXXXX.DWG
XREFS:	XXXXX.DWG

LEGEND:

- PROPOSED STANDARD DUTY ASPHALT PAVEMENT
- PROPOSED HEAVY DUTY ASPHALT PAVEMENT
- PROPOSED CONCRETE
- PROPOSED VEHICLE PARKING SPACES
- PROPOSED COVERED RV SPACES
- PROPOSED UNCOVERED RV SPACES

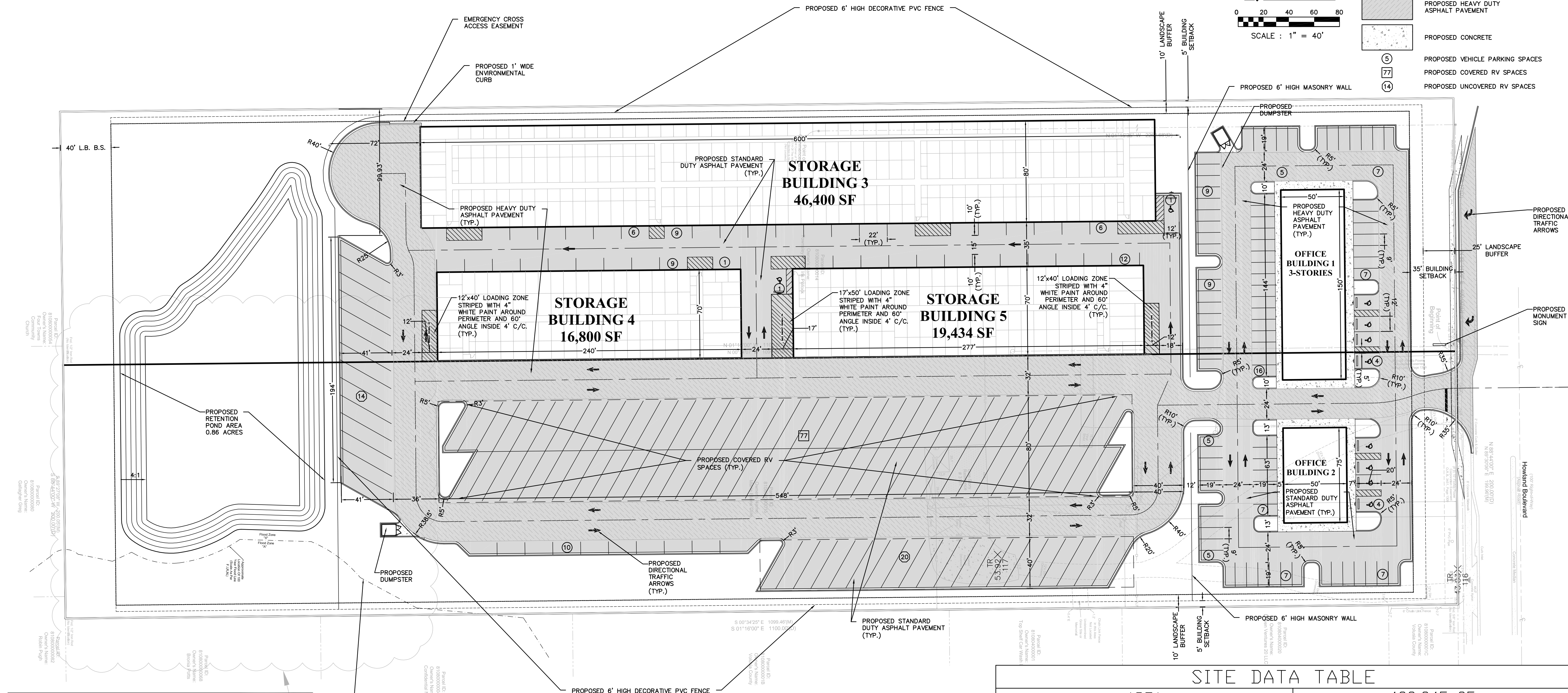

VICINITY MAP
 SCALE: 1" = 1000'

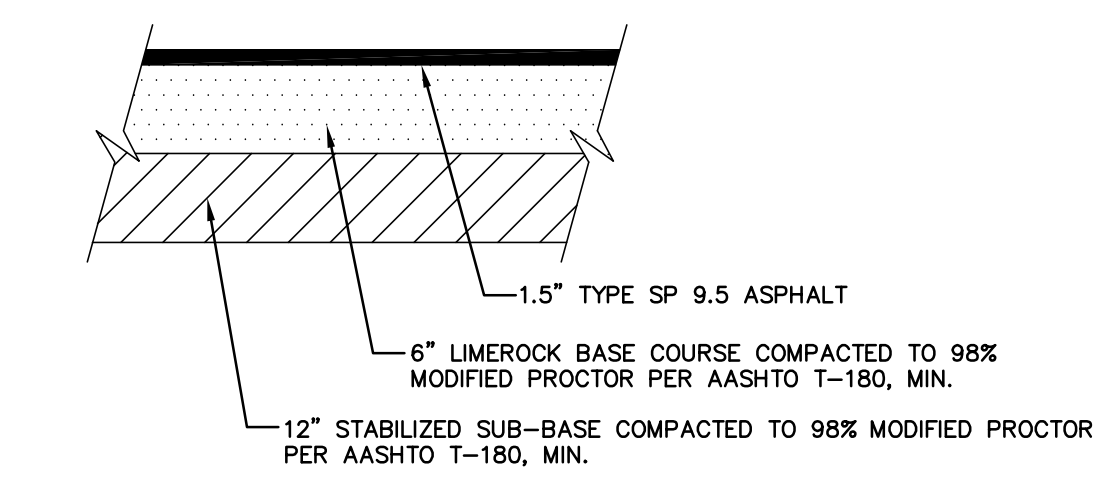

STANDARD DUTY ASPHALT DETAIL
 N.T.S.

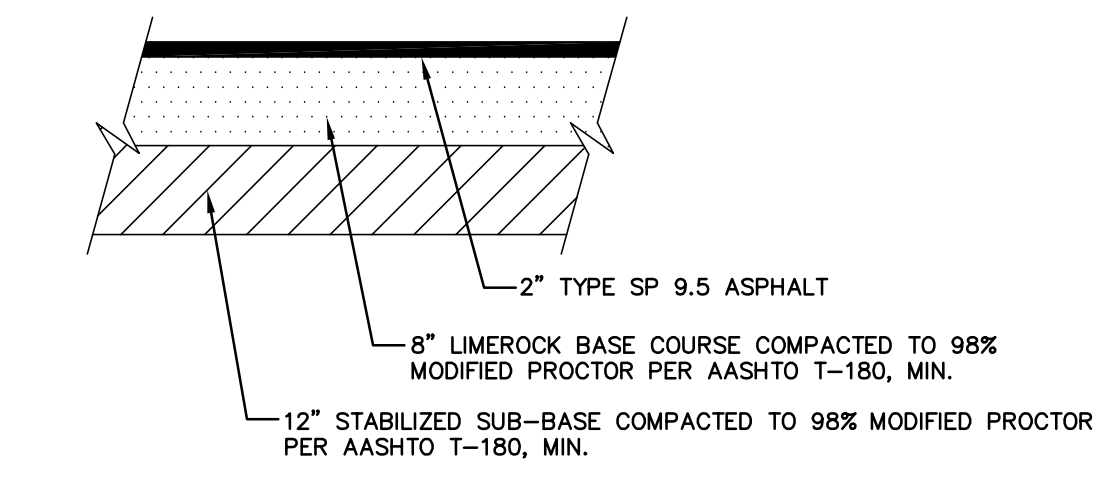

HEAVY DUTY ASPHALT DETAIL
 N.T.S.

SITE DATA TABLE	
AREA	439,945 SF
IMPERVIOUS	287,157 SF
TOTAL PARKING COUNT	256
BUILDING 1	3 STORIES @ 7,500 SF EACH, 22,500 TOTAL
BUILDING 2	3,750 SF
MINIMUM PARKING REQUIRED OFFICE (3.25 SPACES PER 1,000 SF)	86
PARKING PROVIDED OFFICE	93
MINIMUM PARKING REQUIRED STORAGE (1 SPACE PER 10 CUBICLE UNITS)	52
PARKING PROVIDED STORAGE	55
BUILDING 3	46,400 SF
BUILDING 4	16,400 SF
BUILDING 5	19,341 SF
MIN OPEN SPACE REQUIRED %	25%
MIN OPEN SPACE PROVIDED %	25%
FAR	0.55
TOTAL IMPERVIOUS AREA	6.59 AC. (65.27%)
EXISTING FLOOD PLAIN ACREAGE	0.74 AC. (32,276 SQFT.)

E:\22141 LEHA BUSINESS PARK\FINAL ENGINEERING PLANS\CADD\02-22141 ODP.DWG - PRINTED: 12/22/2023 10:29 AM